

SPECIFICATION		
CAPACITY	15,000 LBS	
FOUR COLUMNS C/W SAFETY DEVICES (MECHANICAL/AIR)		
POWER UNIT C/W EL. MOTOR	STANDARD	2HP, 1PH, 230V
	OPTIONAL	2HP, 3PH, 230/460V
ALIGNMENT RUNWAY 2 PCS	SPEED OF RISE	60 SEC.
	LENGTH	202" (226")
	WIDTH	24"
	HEIGHT	7-1/8"
	WHEELBASE	178"
	LIFTING HEIGHT	67-1/2"
INSIDE COLUMN CLEARANCE	124-3/4"	
OVERALL	HEIGHT	77"
	WIDTH	143"
	LENGTH	240-1/2"
OPTIONAL - ROLLING JACKING BEAM		

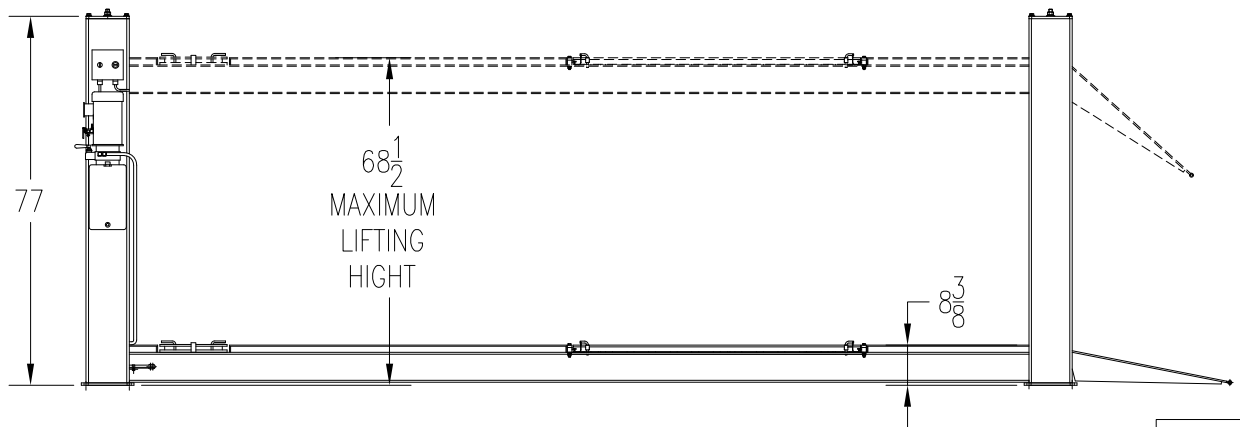
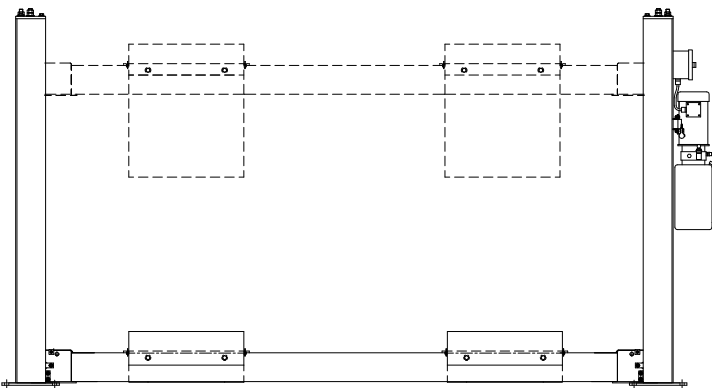
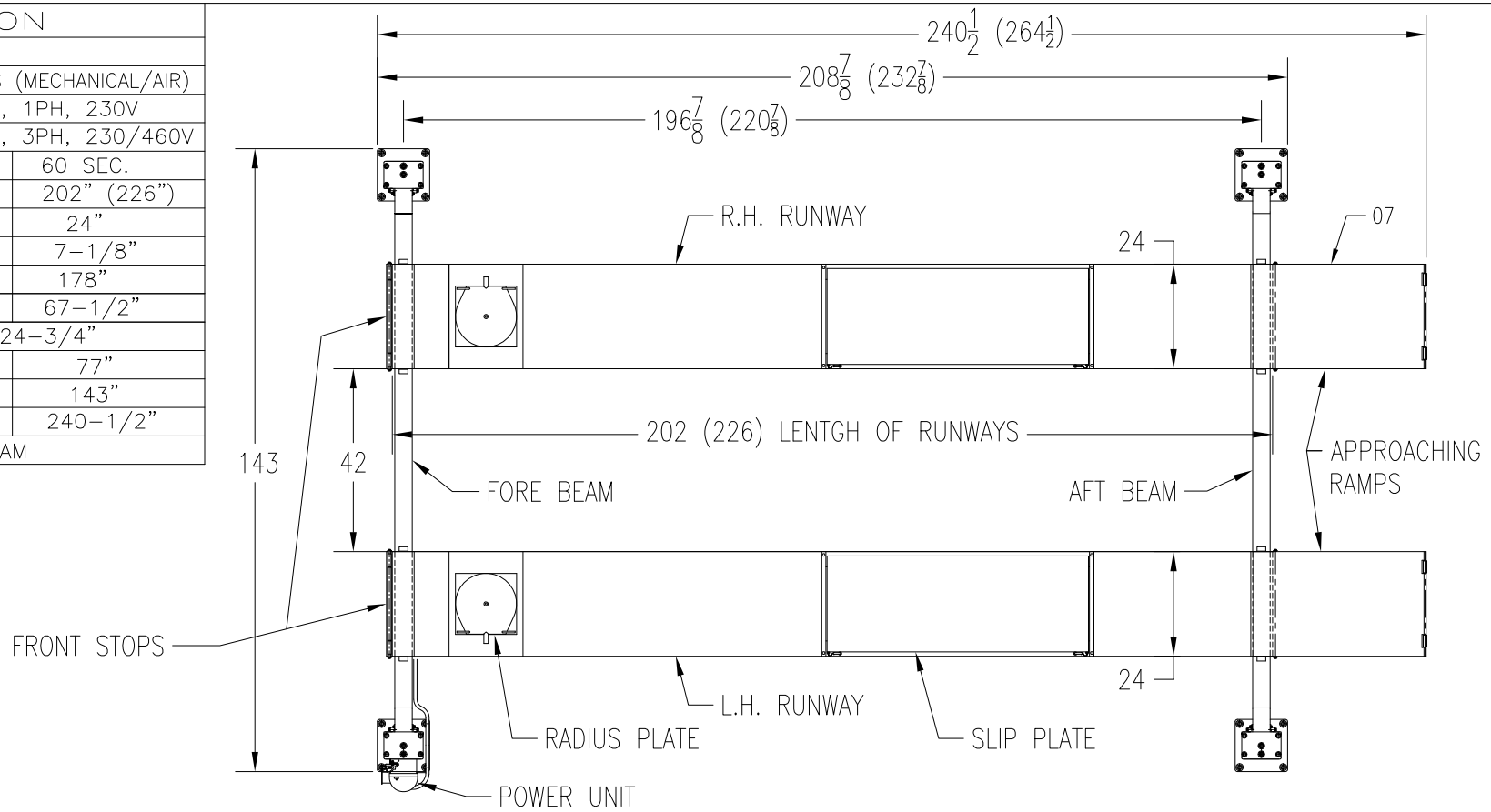

FIG.01

SPECIFICATION		
CAPACITY	15,000 LBS	
FOUR COLUMNS C/W SAFETY DEVICES (MECHANICAL/AIR)		
POWER UNIT C/W EL. MOTOR	STANDARD	2HP, 1PH, 230V
	OPTIONAL	2HP, 3PH, 230/460V
RUNWAY 2 PCS	SPEED OF RISE	60 SEC.
	LENGTH	202" (226")
	WIDTH	24"
	HEIGHT	7-1/8"
	WHEELBASE	178"
	LIFTING HEIGHT	67-1/2"
INSIDE COLUMN CLEARANCE	124-3/4"	
OVERALL	HEIGHT	77"
	WIDTH	143"
	LENGTH	240-1/2"
OPTIONAL - ROLLING JACKING BEAM		

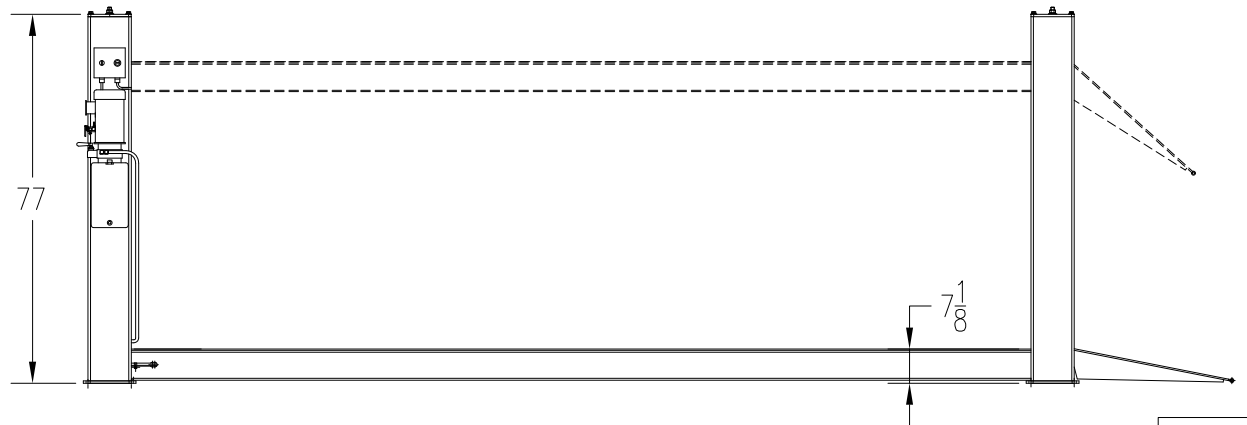
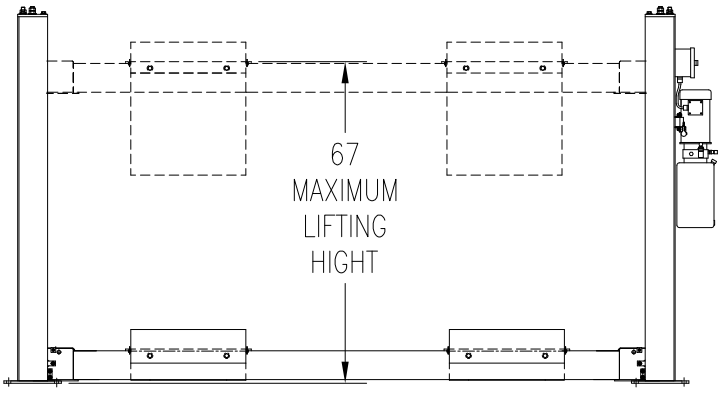
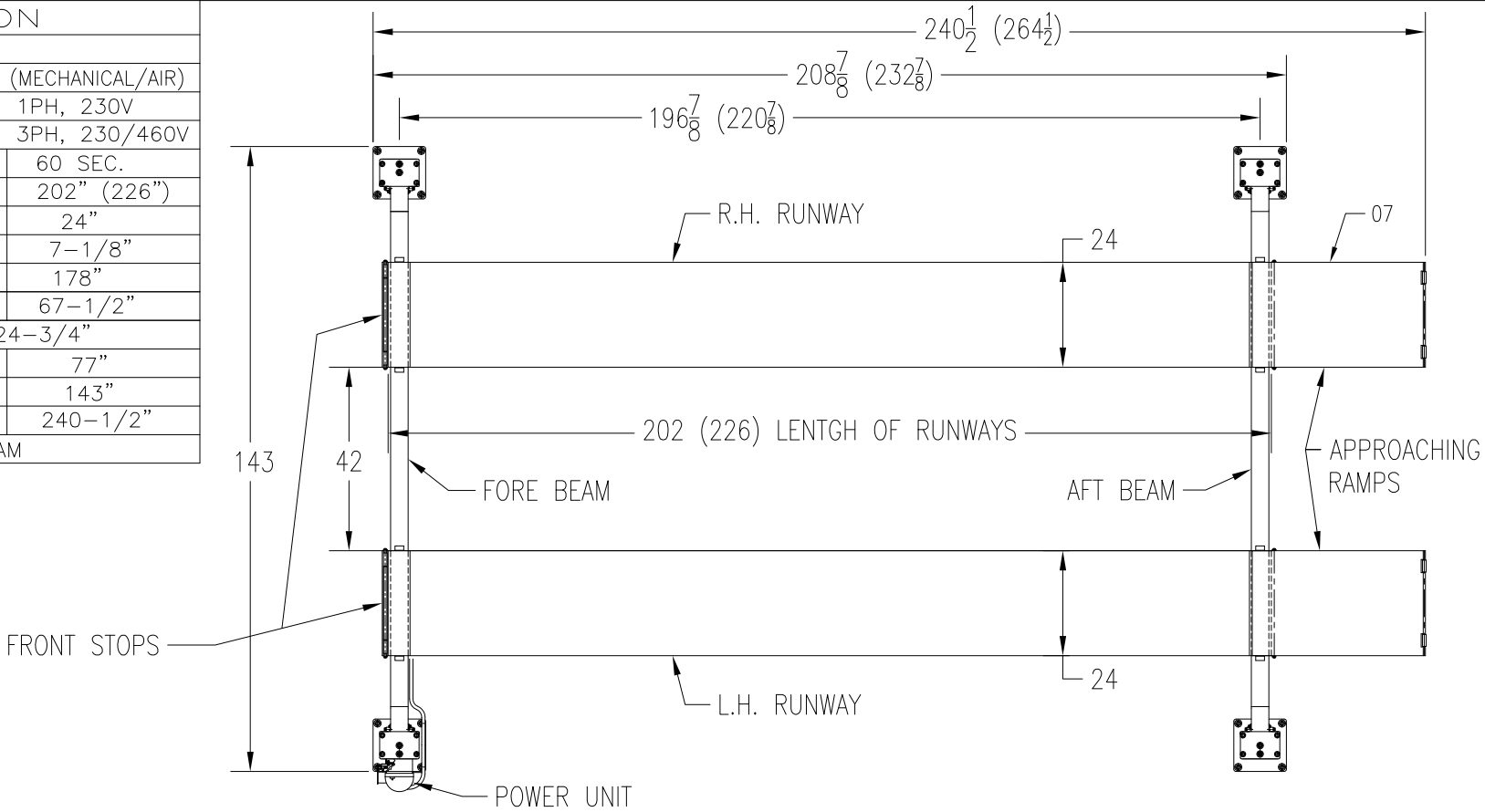

FIG.01