

TWO-POST LIFT MODEL: PK26E

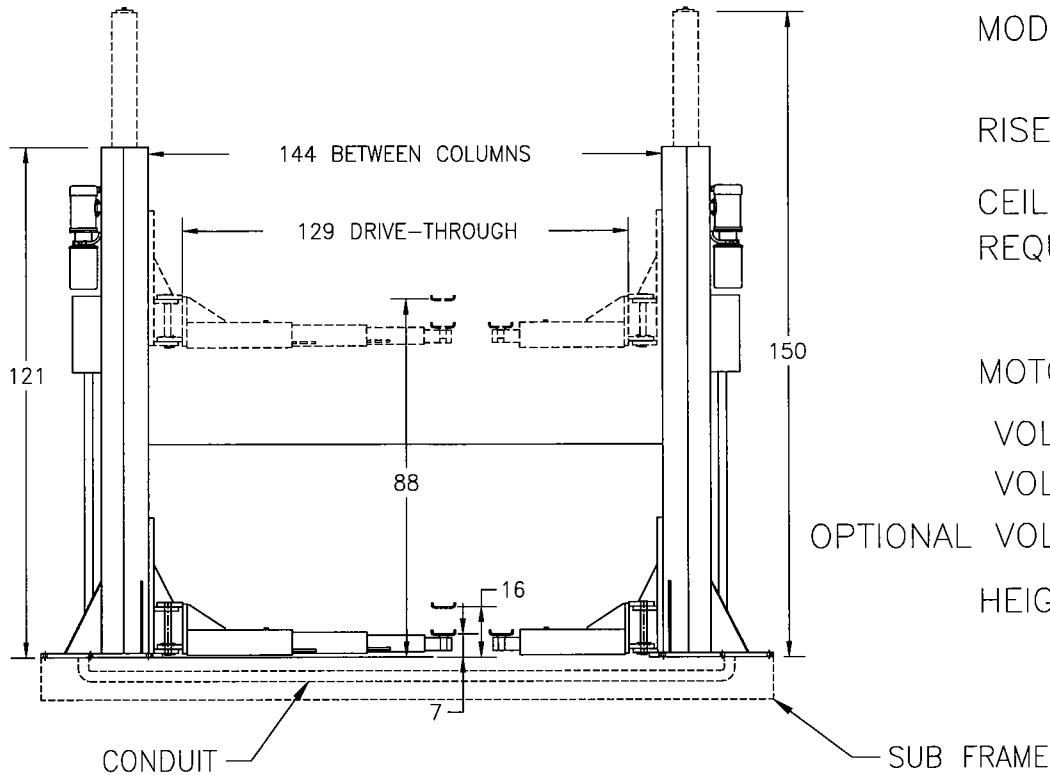

CAPACITY:

MODEL PK26E: 26,000 LBS

RISE: 88"

CEILING HEIGHT
REQUIRED: 160" MIN

MOTORS: 2x2 HP

VOLTAGE 1 Ph.: 208-230V

VOLTAGE 3 Ph.: 230-460V

OPTIONAL VOLTAGE 3 Ph.: 575V

HEIGHT ADAPTERS

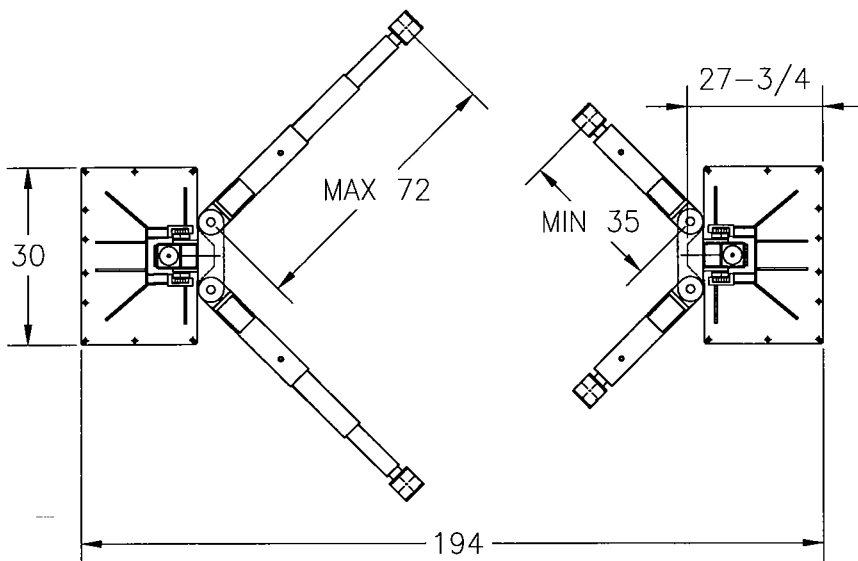

FEATURES:

1. ELECTRONICALLY CONTROL
2. CLEAR FLOOR
3. NO OVERHEAD BEAM
4. NO EQUALIZING CABLES
5. LOW PROFILE ARMS
6. A SINGLE POINT LOCK RELEASE
7. ARM RESTRAIN

TWO-POST LIFT MODEL: PK26E

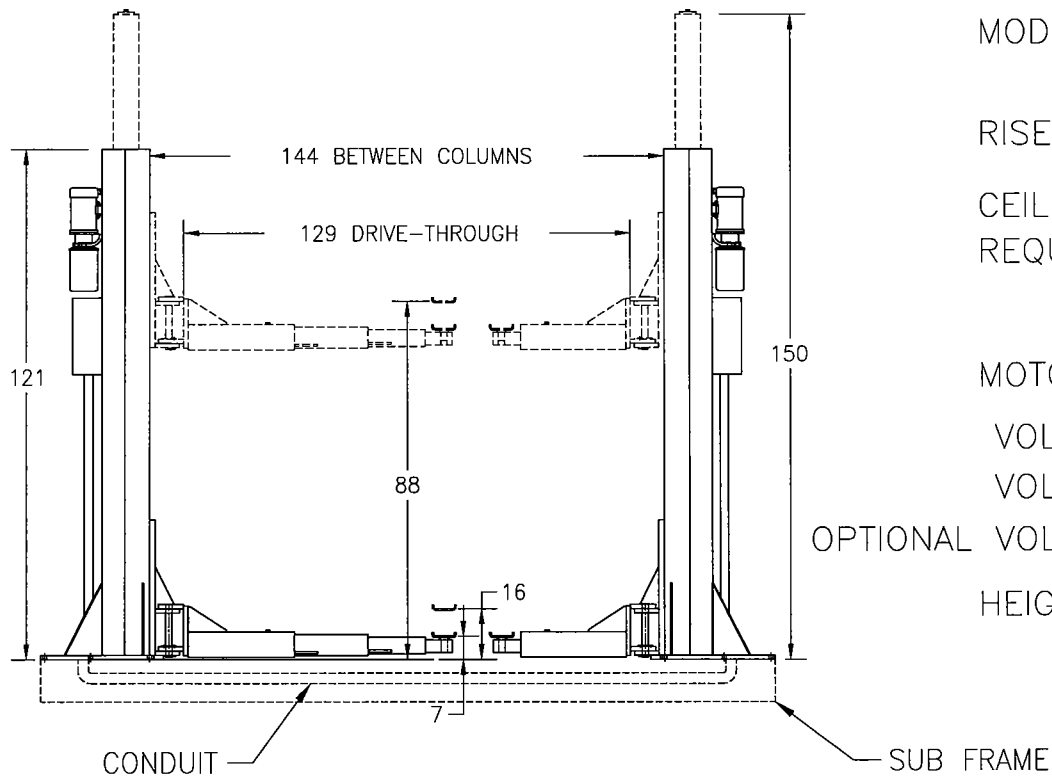

CAPACITY:

MODEL PK26E: 26,000 LBS

RISE: 88"

CEILING HEIGHT
REQUIRED: 160" MIN

MOTORS: 2x2 HP

VOLTAGE 1 Ph.: 208-230V

VOLTAGE 3 Ph.: 230-460V

OPTIONAL VOLTAGE 3 Ph.: 575V

HEIGHT ADAPTERS

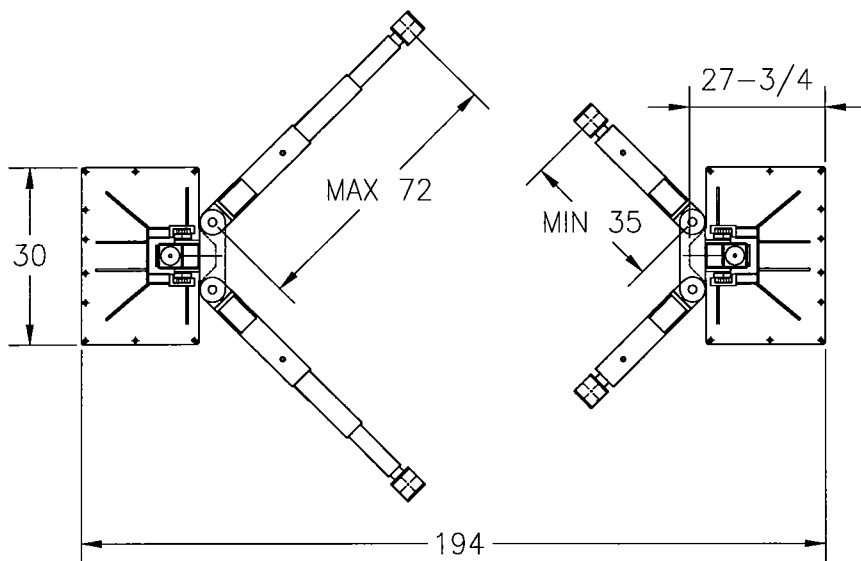

FEATURES:

1. ELECTRONICALLY CONTROL
2. CLEAR FLOOR
3. NO OVERHEAD BEAM
4. NO EQUALIZING CABLES
5. LOW PROFILE ARMS
6. A SINGLE POINT LOCK RELEASE
7. ARM RESTRAIN